Operator's Manual and Parts Catalog

MINI-COLLINS®

PNEUMATIC MODEL

WARNING

Before operating this unit, read and understand the Operator's Manual. Become familiar with the potential hazards of this unit.



WERKZEUGE - TOOLS - OUTILLAGE®

ROTHENBERGER

MAIN DIMENSIONS AND SPECIFICATIONS

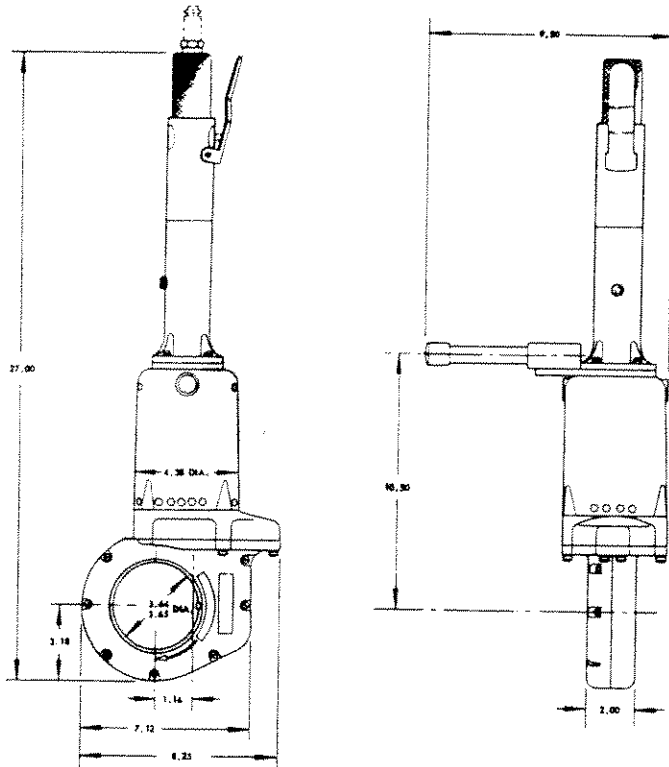

Dimensions are in inches.

Threading Capacity:

Pipe or conduit: $\frac{1}{8}$ " - 2" with drop die heads; up to 6" with geared threaders. Bolt or rod: $\frac{1}{4}$ " - 1" with drop die heads.

Beveling Capacity:

Stainless or steel pipe with a Tri Tool beveler: 12".

Air Supply Requirements:

60-80 CFM at 90-100 P.S.I.

1.70-2.26Cmm at 6.33-7.03 kg/sq cm

Controls:

Operating valve: deadman operating lever turns Amaz-o-Thred off when released.

Direction valve: rotary handle control; for forward-reverse.

Motor:

High torque vaned reversible motor.

Performance:

Output torque: 600 foot pounds forward or reverse.

Weight:

25 pounds/11.34 kilograms

Gears:

Heat treated helical gear, double lead screw and bronze worm gear construction, reduction ratio: 349:1.

INTRODUCTION

Your new Amaz-O-Thred is a powerful tool which will thread $\frac{1}{8}$ " to 2" pipe or conduit using your own die heads. As a power drive with a geared threader it will thread $2\frac{1}{2}$ " to 4" pipe. With adapters and accessories available, the Amaz-O-Thred will perform a wide range of tasks requiring a high-torque, low rpm drive unit.

OPERATOR SAFETY INSTRUCTIONS

Although this machinery is manufactured for safe dependable operation, it is impossible to anticipate those combination of circumstances which could result in an accident. The following instructions are recommended for safe operation of the machine.

The operator is cautioned to always practice "Safety First" during each phase of use, including setup and maintenance of this unit.

1. **Read and understand the Instruction Manual.** Before operating or performing maintenance on this machine, read carefully the operator's manual. Become familiar with the machine's operations, applications and limitations. Be particularly aware of its specific hazards. Store the operator's manual in a clean area and always at a readily available location. Additional copies at no charge are available upon request by writing Collins Machinery Corporation.

2. **Prevent accidental startings.** For safety, the Amaz-O-Thred is equipped with a dead man safety valve which automatically shuts off the machine when the operator lever is released. Become familiar with the switches and their use prior to operating machine.

3. **Keep work area clean.** Keep the work area clear of clutter. Remove all oil or coolant spills.

4. **Wear proper clothing.** Loose clothing can get easily entangled in moving parts. When operating machine, do not wear unbuttoned jackets, loose sleeve cuffs, neckties, long hair, etc. Safety glasses and shoes should be worn.

5. **Always maintain machine.** Keep machine clean and maintained for safe dependable operation. Follow lubricating instructions. Report any unsafe condition for immediate correction.

6. **Keep alert.** Do not operate machine if ill or drowsy from medication or fatigue. Avoid horseplay around equipment and keep bystanders a safe distance from equipment.

7. **Operate on switch side only.** Maintain proper balance and footing when operating machine. Never reach across moving parts or material being worked on. Controls should always be accessible to operator. Keep hands and tools away from moving parts.

8. **Operate in proper environment.** Wear hearing protection in noisy shop operations. Ensure proper illumination in work area.

9. **Do not misuse machine.** Perform only the functions for which the machine is designed. Do not force machine.

10. Use recommended accessories only. Consult operator's manual for recommended adapters. Use of improper adapters may result in injury.

THREADING OPERATING INSTRUCTIONS

1. CAUTION: Use of hearing protection device is mandatory at all times when operating the pneumatic Amaz-O-Thred.

2. Check the air source to be sure that 60-80 cfm of air at 90-100 psi is available.

3. Screw stationary support rod into fitting on the side of the Amaz-O-Thred. (Fig 1).

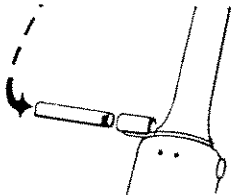

FIGURE 1

4. Practically all makes of drop die heads may be used. Consult the adapter table for the correct adapter to be used.

Note: If a 12R Ridge drop head is used, a 1/4" segment of the snap ring must be removed (Fig. 2) to provide an opening for the Amaz-O-Thred drive key.

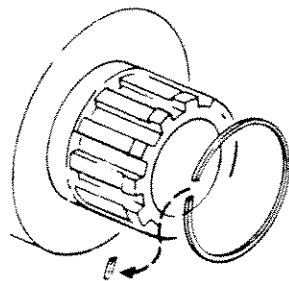

FIGURE 2

5. Insert die head or adapter into the Amaz-O-Thred on the side showing directional arrow. Push die head on adapter squarely into the drive gear until retaining spring catches securely.

6. Apply Thred-O-Matic cutting oil to pipe or conduit before starting thread; oiling should be continued generously while threading.

7. Place the Amaz-O-Thred handle in the right hand and the left hand on the gear housing.

8. Put the drive on the pipe as would be done in operating a hand ratchet die stock. Lift the handle to a vertical position.

9. With palm of the left hand against the face of the die head, center the dies on the end of the pipe.

10. While pressing the heel of the left hand firmly against the die head, bring the handle down quickly with the right hand, forcing the dies to bite into the pipe.

11. Place 14" wrench on pipe (Fig. 3) and rest handle on stationary support rod. Be sure to leave ample space between Amaz-O-Thred and pipe wrench; space must be greater than length of thread to be cut.

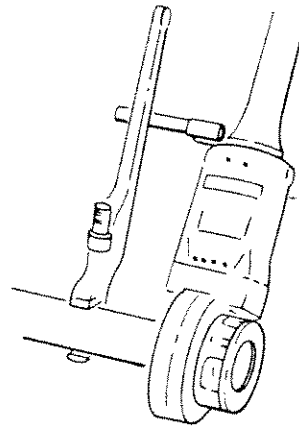

FIGURE 3

12. The Amaz-O-Thred is equipped with two control valves for your safety. The operating lever control turns on the Amaz-O-Thred while the rotating handle controls the forward and reverse of your tool.

13. **Caution:** Hold onto the Amaz-O-Thred handle firmly to resist initial reversing torque. Pipe wrench should be reset to permit the drop head to back off quickly.

THREADING WITH GEARED THREADERS

1. Be sure pipe to be threaded is properly secured in vise and that the geared threader is adjusted according to the manufacturer's operating instructions.
2. Insert No. 1041A square drive adapter into the Amaz-O-Thred as is explained in Step 3, Page 2.
3. Slip 1041A adapter (installed in Amaz-O-Thred) into the drive shaft of geared threader and tighten the adapter set screw.
4. Before turning on Amaz-O-Thred, push the handle down so that the operator's elbow is straight and the weight of the operator is squarely above the handles.
5. Be sure the Amaz-O-Thred is operating in the correct direction.
6. Hold the Amaz-O-Thred handle in one hand and apply cutting oil with other.
7. When threading is completed, switch direction the reverse of what was required for threading.
8. Be sure geared threader dies are free from end of pipe before removing adapter.

MAINTENANCE AND REPAIR

AIR FILTER AND LUBRICATOR

The air hose supply line **must** be equipped with an air filter and lubricator. When operating the pneumatic Amaz-O-Thred continuously, the oil reservoir should be checked daily. Failure to use

ADAPTERS

TO DRIVE	USE ADAPTER NO.	SEE NO.
Armstrong 292R	12133	2.
Central C	13145	3.
Central Nr. C	13146	3.
Nye N60	13147	3.
Nye N12	No adapter needed	-
Ridgid 00-R	13146	3.
Ridgid 111-R	13145	3.
Ridgid 11-R	13152	4.
Ridgid 12-R	No adapter needed	-
Reed 72-82	13149	3.
Toledo 12	13150	1.
Toledo 11	13151	3.
Virax 62	13152	4.
7/8" Square Shaft	13153	5.
1" Square Shaft	13154	5.
1 1/4" Square Shaft	12307	5.

an air filter and lubricating system will result in damage to the air motor and void the warranty.

OIL RESERVOIR

The pneumatic Amaz-O-Thred is equipped with an oil reservoir (located in the handle). The oil level should be checked periodically and kept filled with a 30 weight oil.

LUBRICATION

It is normal for some grease to seep from gear case around drive bushing to provide adequate lubrication. Fill gear case periodically with Gear Lube No. MC-519. Access to gear case is gained by removing the 1/8" pipe plug on the side of the gear case.

CUTTING OIL

To assure clean threads and long wear of chasers use Collins sulphur base cutting oil.

MOTOR

Lubrication is not required as the motor has sealed ball bearings.

SERVICE

Should you have questions covering your tool, contact your nearest Collins service center.

1.



2.



3.

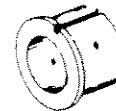

4.



5.



PNEUMATIC

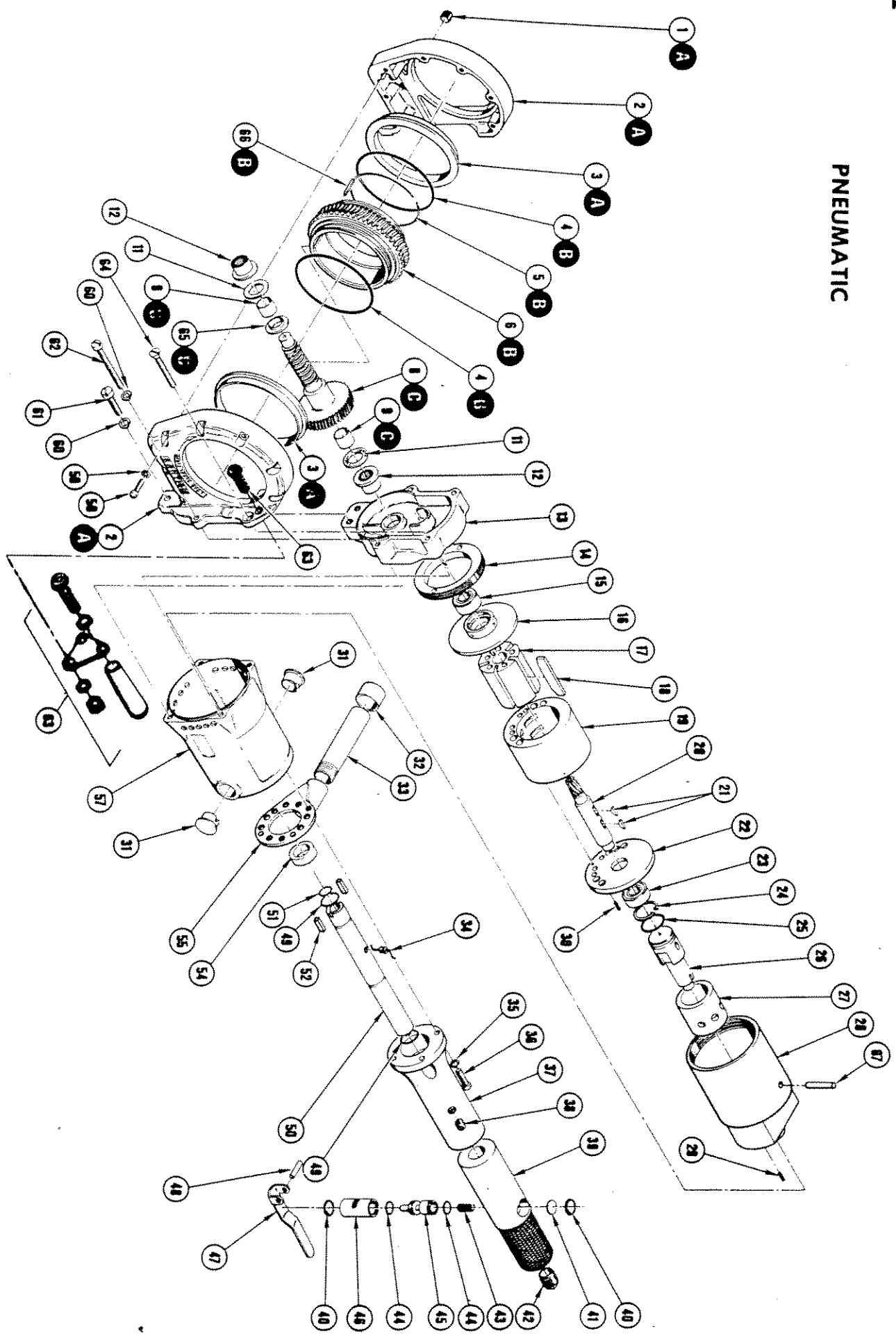

PNEUMATIC

PARTS

1.	13140	Plug, Pipe, Slotted, 1/8"-27 NPT	36.	K-1109	Screw, Machine, 1/4-20 x 1" Lg. (4)
2.	13137-1	Housing, Drive Gear	37.	12357	Handle Half, Front
3.	13138	Bushing, Shoulder, Drive Gear Hsng. (2)	38.	13423	Plug, Pipe, 1/8-27 NPT
4.	13114	Packing, Preformed ("O" Ring)(2)	39.	12356	Handle Half, Rear
5.	13121	Spring, Die Hd. Retainer	40.	13345	Ring, Retaining, Internal
6.	13161-1	Gear, Worm Wheel	41.	13399	Disc, Valve
7.	—	Worm Shaft	42.	13451	Plug, Pipe, Plastic, 1/2-14 NPT
8.	13162	Race, Bearing Inner (2)	43.	13452	Spring, Compression, Valve
9.	13118	Washer, Thrust, Bearing (2)	44.	13346	Packing, Preformed ("O" Ring)
10.	—	Bearing, Needle (2)	45.	12364	Valve
11.	13117	Support, Motor	46.	12365	Bushing, Valve
12.	13116	Ring, Locking, Threaded	47.	12368	Lever, Valve Operating
13.	13101	Bearing, Ball	48.	U-715	Pin, Spring, Trigger Lever, 3/16" x 1" Lg.
14.	12361	Plate, Bearing Support, Front	49.	12619	Packing, Preformed ("O" Ring) (2)
15.	13344	Rotor, Air Motor	50.	14306	Shaft, Valve Control
16.	12358	Vane, Air Motor (5)	51.	13342	Packing, Preformed ("O" Ring)
17.	12360	Cylinder, Air Motor	52.	12290	Key, Square, 1/8 x 1/2" LG. (2)
18.	12370	Gearshaft, Air Motor	53.	—	Coupling, Shaft
19.	12355	Key, Woodruff, 1/8" x 5/8" (2)	54.	14302	Bracket, Torque Rod
20.	12367	Plate, Bearing Support, Rear	55.	13105	Housing, Motor, Outer
21.	1338	Bearing, Ball	56.	—	Screw, Mach., Fil. Hd., No. 10-24 x 7/8" Lg. (7)
22.	12359	Ring, Retaining, Internal	57.	14303	Lockwasher, Tooth, No. 10 (7)
23.	13141	Packing, Preformed ("O" Ring)	58.	K-910	Lockwasher, 1/4"
24.	13343	Valve, Air Motor	59.	CB-107	Screw, Mach., Fil. Hd., 1/4-20 x 7/8" Lg. (2)
25.	13072	Housing, Sleeve, Air Valve	60.	C-109	Handle Assy., Carrying
26.	14305	Housing, Motor, Inner	61.	K-1108	Screw, Mach., Flat Hd., 1/4-20 x 2 1/4" Lg. (2)
27.	12369	Pin, Spring, 1/8" x 7/16" Lg.	62.	K-1115	Support, Bearing, Worm Shaft
28.	14304	Pin, Spring, 3/16" x 1/2" Lg.	63.	12327	Key, Square, 1/4"
29.	U-406	Plug, Hole, 1/2"	64.	J-1114	Pin, Dowel, 1/8 x 7/8 LG.
30.	U-707	Cap, Torque Rod	65.	13115	Housing Assembly
31.	13338	Rod, Torque	66.	12618	Gear Assembly, Worm Wheel
32.	13155	Screw, Wick	67.	0-105	Worm Shaft Assembly
33.	13107	Washer, Lock, 1/4"	SUBASSEMBLIES		
34.	13347		A	13137	Motor & Handle Assembly
35.	C-109-HC		B	13161	(Includes Items # 14 Thru 67)